

# CATERPILLAR TURN TWIN POWER LIFT

MODEL **TWPF Series**

We supply wide variety of models for many kinds of vehicle types and applications.



**10t**  
(5t+5t)  
2-post type

**12t**  
(6t+6t)  
2-post type

**30t**  
(15t+15t)  
2-post type

**45t**  
(15t+15t+15t)  
3-post type

**60t**  
(15t+15t+15t+15t)  
4-post type



In photo: 10 t, 2-post type

**10t**  
(5t+5t)  
2-post type

**12t**  
(6t+6t)  
2-post type



**30t**  
(15t+15t)  
2-post type



**45t**  
(15t+15t+15t)  
3-post type



**60t**  
(15t+15t+15t+15t)  
4-post type

It can maintenance two small trucks at the same time by parallel.

# Flat Floor

Flat floor makes operation more safety.

# Lightweight attachments

A wide range of attachment support various vehicle types.

## CATERPILLAR TURN

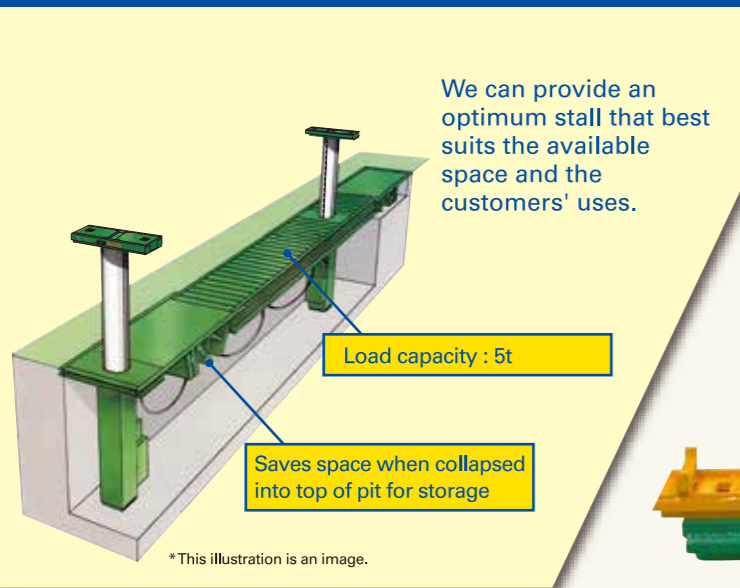

Floor level is flat even when arms are raised and lowered

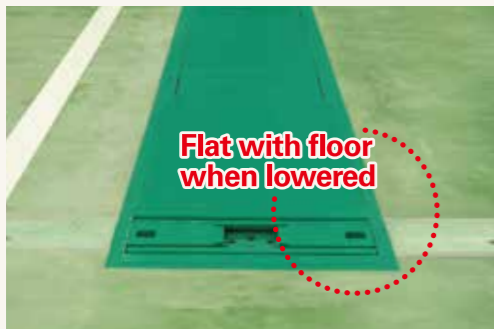

Raising flat cover makes floor flat

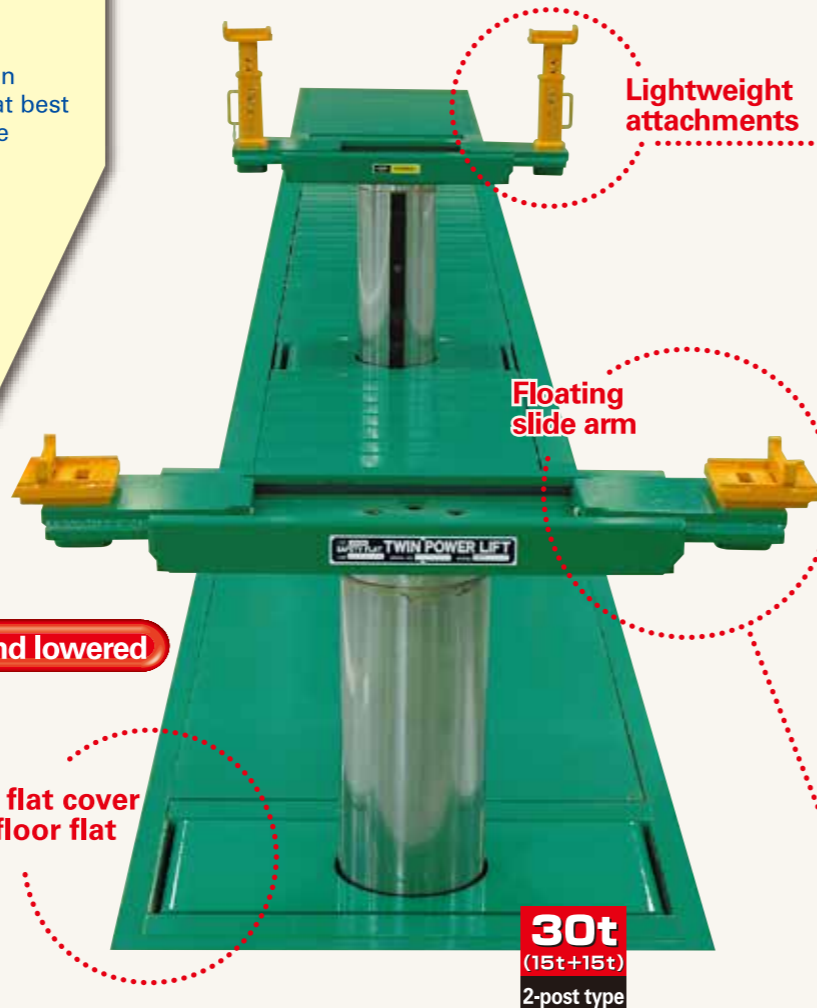

Light weight attachments makes the operation smoothly by one operator.



## Attachments

Truck setting: For trucks (I,IV,V,VI) Bus setting: For buses (II,IV,VI)  
Choose proper setting kit when ordering.

### Front attachments



### Rear attachments

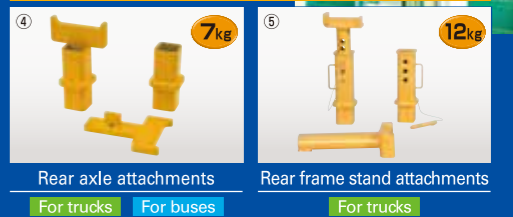

※ Attachment weights are for one side only.  
※ Attachments can be provided to suit customer needs.

## Powerful Lifting and Reliable Setting

Uses time-tested high-pressure cylinders (with hard chrome plating).  
Internal cylinder method ensures even greater safety.



## Safety functions

This unit has these safety equipments.

- Prevention of natural lower (mechanical lock and fuse valve)
- Protection of hydraulic circuits (release valve)
- Emergency stop switch
- Auto power off function
- Circuit diagnostics function



## Operability



Remote controller (standard equipped)

## Easy maintenance

Sections of the CATERPILLAR can be readily removed to fully open the pit for easy inspection.





### External view

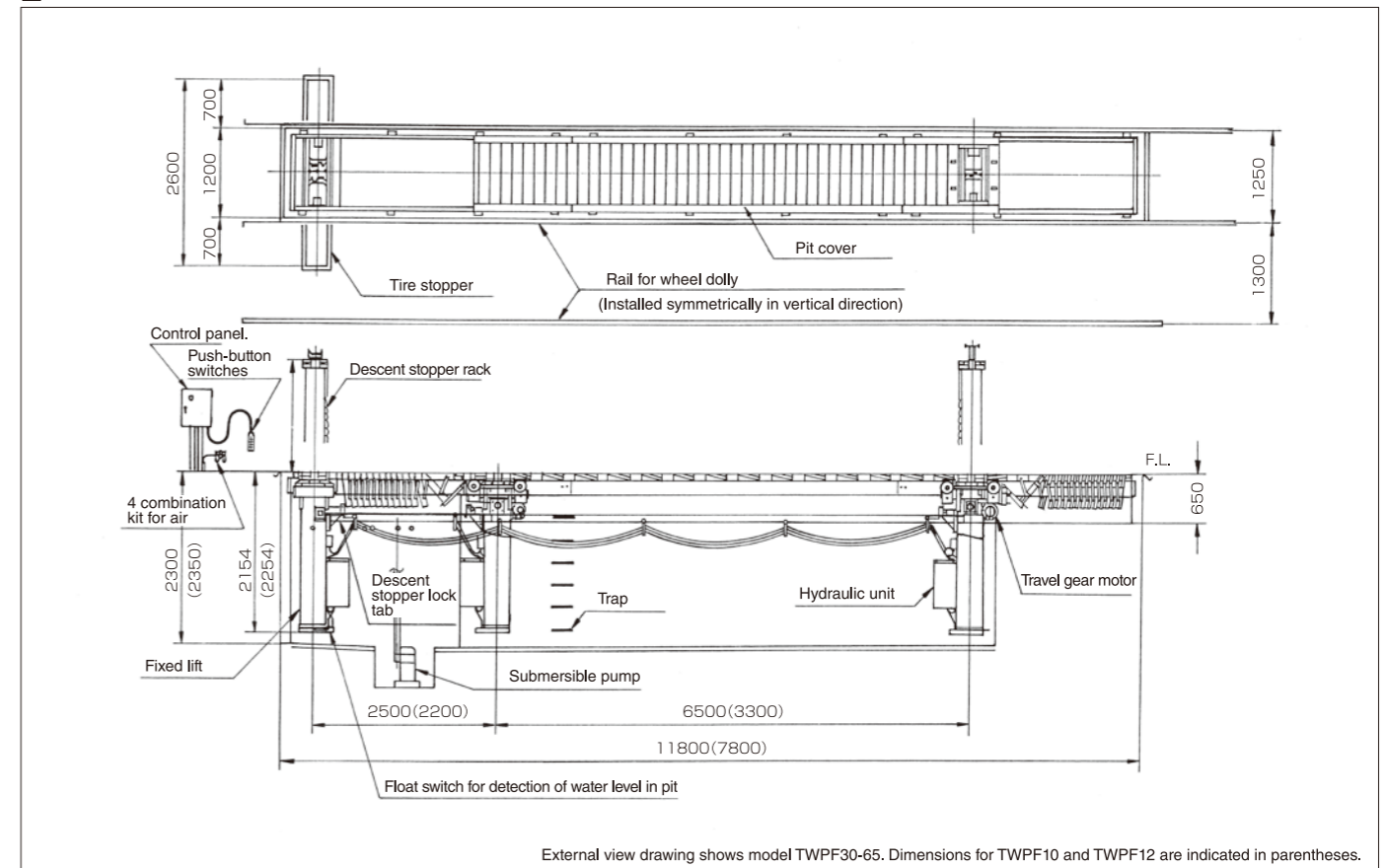

### Specifications

Model	TWPF10	TWPF12	TWPF30-65	TWPF45	TWPF60
Capacity (t)	10(5+5)	12(6+6)	30(15+15)	45(15+15+15)	60(15+15+15+15)
Lifting height (mm)	1,500				
Lift distance (mm)	Min2,200 to Max3,300		Min2,500 to Max6,500	Varies according to specifications	
Lifting up. (s)	72/60(50/60Hz)		84/70(50/60Hz)		
Lifting up motors (kW)	1.5 x 2		2.2x2	2.2x3	2.2x4
Motor (kW)	0.2		0.4	Varies according to specifications	
Lift remote control cores (cores)	10			12	
Airpressure (MPa)	0.5 to 1.0				
Pit cover	Caterpillar turn				

※Please ask to us for details about models TWPF45 and TWPF60.

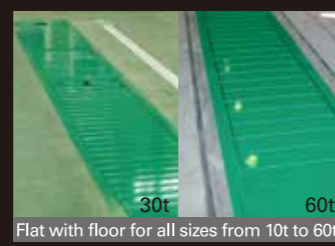

### Combining devices

#### Power saving equipment

##### Propeller shaft lifter APSL-150H

- Assist for install / remove Propeller shafts / Stabilizers
- Capacity: 150kg

##### Transmission jack AMJ-1000A

- Assist for install / remove Transmission/Gearbox.
- Capacity: 800kg

##### Transmission lift AML-1000A

- Assist for install/ remove Transmission/Gearbox.
- Capacity: 1000kg

##### Clutch unit lifter ACL-100

- Assist for install/remove Clutch unit/cover.
- Capacity: 100kg



#### Undercarriage equipment

##### Wheel dolly AWD-2009CL

- Assist for install/ remove tires.
- Capacity: 500kg



##### Rail wheel dolly AWD-2009R

- Assist for install/ remove tires.
- Capacity: 500kg



■ Before using this product, ensure correct use by carefully reading **the safety caution points described** in the manual provided at delivery.

## ANZEN MOTOR CAR CO., LTD.

4-16-25 Shibaura, Minato-ku, Tokyo Japan 108-0023  
 TEL +81-3-5441-3412 FAX +81-3-5441-8848  
 Website: <http://www.anzen.co.jp/english/>